

Meter Test Equipment



E-Mobility Testing
Calibration of Electricity Meters applied in
Electric Vehicle Supply Equipment (EVSE)

While climate change rose to the top of many governments' agendas and consumers' attitudes have evolved, adoption of electric vehicles (EVs) is becoming a worldwide trend.

The combined annual sales of battery electric vehicles and plug-in hybrid electric vehicles tipped over the two-million-vehicle mark for the first time in 2019, while EVs staked their claim on a 2.5% share of all new car sales. US car manufacturer "Ford" announced that from 2030 they intend to sell only EVs in Europe while OEM "GM" goes even further supplying solely EVs by 2035.

The further development and implementation speed may vary between different regional markets while the long-term outlook for EVs remains strong triggered by factors such as consumer sentiment, policy and regulation, car manufacturers' strategy and the role of corporate companies.

It's expected that the global EV market grows by a CAGR of 29% over the next ten years: Total EV sales growing from 2.5 million in 2020 to 11.2 million in 2025, then reaching 31.1 million by 2030. By then EVs would secure approximately 32% of the total market share for new car sales.¹⁾

The income from taxes on gasoline and diesel for road maintenance will decrease in future as the proportion of EVs increases. It is therefore likely that taxes will also be raised per kWh of electrical energy loaded to the EV. This will require the use of certified AC and DC electricity meters in Electric Vehicle Supply Equipment (EVSE), widely known as "charging stations", as this is for example already the case in Germany.

¹⁾ Source: Deloitte Insights: Electric vehicles. Setting a course for 2030 (2020).

Therefore, the correct registration and billing of the charged electrical energy to the customer is becoming even more important while also a regular calibration of the EVSE on-site will be mandatory as this is the common case at fuel pumps.

Having a dense network of EVSE is one of the most important factors enabling the successful spread of EVs. While the availability of EVSEs is growing steadily, the reliability, efficiency and accuracy is often not yet addressed. Since the conformity with calibration law is also valid for EVSE, this must be checked periodically.

To maximize the opportunities presented by the growing demand for EVs and EVSEs infrastructure, utilities, meter manufacturers and meter service providers all over the world should examine the priorities they have and ask themselves key questions such as:

- How can we plan and build up an efficient and reliable EVSE infrastructure?
- What are the electricity meters being used in EVSE and how can we test its accuracy and correct registration?
- How can we make sure to provide a secure and reliable charging infrastructure while the consumer is being charged for the accurate amount of consumption?

Addressing such questions and challenges, MTE came up with different solutions along e-mobility testing for customers such as utilities, meter manufacturers and meter service providers.

(1) Calibration of built-in AC electricity meters on-site

For customers such as utilities, meter service providers or operators of EVSE, MTE developed the **eMOB I-32.3 AC test adapter** which enables three-phase precision AC current measurement up to 32 A and three phase AC voltage measurement at the outlet of an AC charging station. This set up allows the precise measurement of the energy charged to the accumulator of the EV considering also the voltage drop between the built-in electricity meter and the outlet of the charging station, where the power is available for the customer. In combination with the **PWS 2.3 genX Portable Working Standard** from MTE, the eMOB I-32.3 AC can be connected to any EVSE to retrieve all relevant performance data, thus realizing a test system of accuracy class 0.1 and making it possible to test the installed energy meter and determine the existing power loss.

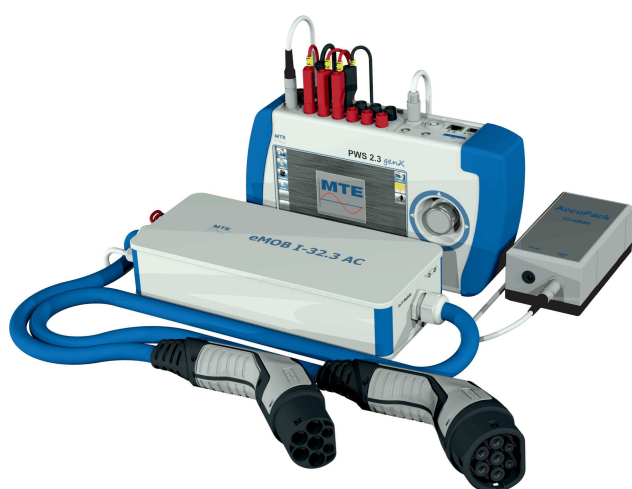

Advantages

- Portable working standard accuracy class 0.1
- Easy and fast connection between EVSE and EV
- Operation with rechargeable battery (option) connected to 12 VDC input, if auxiliary supply connection is missing
- Charging current three-phase up to 32 A (up to 22 kW power)
- User-friendly functions such as integrated operation manual
- Large 7" touch screen color display and web server for remote display of graphical user interface and remote control of the unit

Application example

The adapter is used to test the energy measurement accuracy of the EVSE by comparison of the energy measured by the built-in AC electricity meter with the energy measured by the Portable Working Standard PWS 2.3 genX with an eMOB I-32.3 AC test adapter at the output of the charging station.

This can be done by a so-called register test or error measurement as shown in the example below.



The eMOB I-32.3 AC test adapter is first connected to the PWS 2.3 genX and then connected to the EVSE and the EV.

Register test

First a charging process at the EVSE is initialized but not started yet. Then a register test at the PWS 2.3 genX is initialized by entering the start energy reading, either zero for charged energy or the actual energy register reading of a built-in electricity meter shown on the display or in an App or through a window in the EVSE.

Calibration of built-in electricity meter on site

Then the energy measurement is started at the PWS 2.3 genX. Now the charging of the EV at the EVSE is started and the amount of charged energy is observed and should reach at least 200 units of the last indicated digit before the charging is stopped at the EVSE. The energy measurement is then stopped at the PWS 2.3 genX and the charged energy or energy register reading indicated is entered as end reading and the error of the EVSE energy measurement unit compared to the PWS 2.3 genX + eMOB I-32.3 AC adapter is calculated and indicated.

Error measurement

If the EVSE has a built-in AC electricity meter equipped with a test output, which generates LED pulses or electrical pulses proportional to the power, an error measurement can be performed as shown in the example. The charging of the EV must be started at the EVSE and running during the whole test.

One pulse represents a defined energy quantity, e.g. 1 Wh. In the example shown this test LED of the AC electricity meter is visible through a window in the charging station.

A scanning head connected to the PWS 2.3 genX is mounted over this window and adjusted to detect the LED pulses, which then are counted by the PWS 2.3 genX.

The energy registered by the AC electricity meter, based on the counted LED pulses, is later compared with the reference energy measured by the PWS 2.3 genX + eMOB I-32.3 AC test adapter and the error of the energy measurement of the EVSE is calculated and indicated.

With our universal test software CALegration, running on a tablet or portable PC, a predefined test procedure can be used to guide the operator through the different test steps, like data entry, register test, error measurement, no load test etc., including the evaluation of the results and the generation of a test report.

(2) Calibration of built-in DC electricity meters on-site

In general, the principle and application are the same as applied at AC electricity meters. For this set-up, MTE developed another test adapter **eMOB I-200.1 DC** with CCS Type 2 inlet (IEC 62196-3) and DC charging cable with CCS plug.

In combination with a reference standard, such as the new PWS 3.3 genX, the setting can measure single-phase DC voltage up to 1000 V, DC current up to 200 A and resulting DC power/energy.



Advantages

- Portable working standard accuracy class 0.05
- Easy and fast connection between EVSE and EV
- Battery operation (option), if auxiliary supply connection is missing
- Field testing of EVSE up to 1000 VDC | 200 ADC (up to 200 kW power)
- User-friendly functions such as integrated operation manual
- Large 9" touch screen color display and web server for remote display of graphical user interface and remote control of the unit

(3) Calibration of built-in DC electricity meter on-site with simulated load (under development)

Solution concept

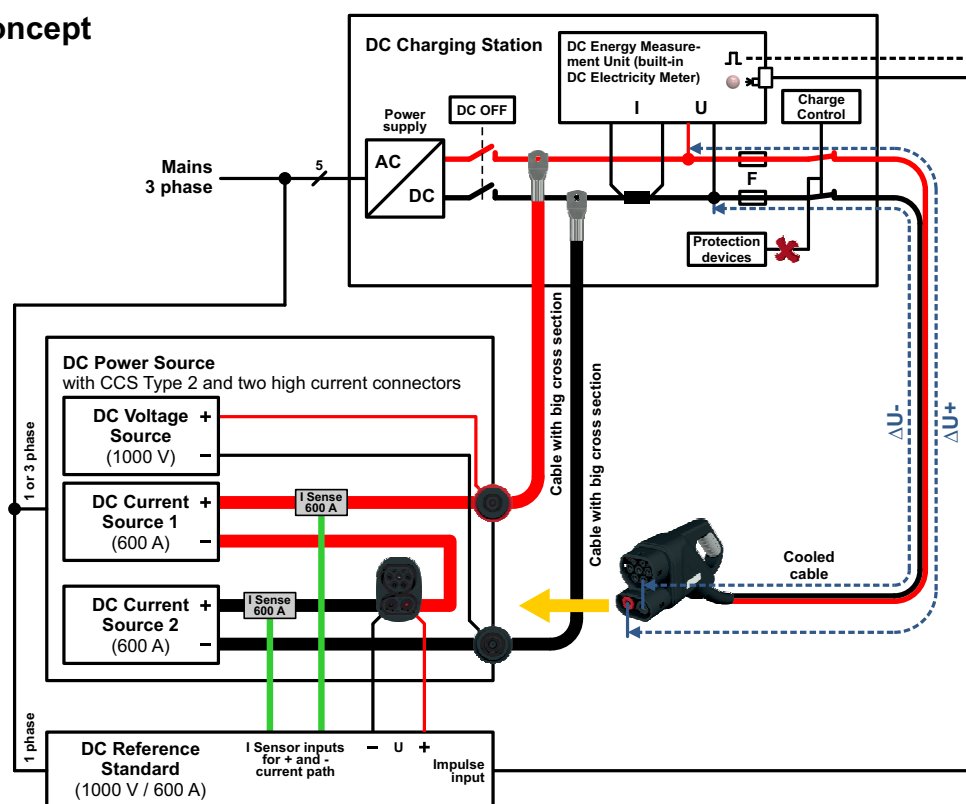

A DC voltage source (up to 1000 V) and two DC current sources (up to 600 A) are used to simulate a variable DC load (up to 600 kW) and to simulate the losses between the inside measurement unit and the end of the charging cable (voltage drop ΔU).

The voltage source and the current source used for the path **DC-** with the current measurement element simulate the DC power for the Energy Measurement Unit inside the EVSE, which must be separated from the inside DC power source (DC OFF) for this test (phantom load principle).

The second current source is used to simulate the same voltage drop ΔU on the second current path **DC+**, as this would be the case with a real load with the same current.

A DC reference standard measures the DC voltage at the CCS Type 2 car inlet integrated in the test equipment and the DC current in the path **DC-** with the current measurement element and registers the DC energy as transferred to the EV to perform register tests and, if a pulse output (optical or electrical) is available, to perform error measurements also.

This allows to calibrate the built-in DC Energy Measurement Unit or DC electricity meter on-site at different load points as in the laboratory.

This test principle requires access to the EVSE (operation of mains circuit breaker, possibility to separate the DC power source from the measurement unit, possibility to connect voltage and current sources on **DC+**, **DC-** paths before the measurement unit, connection to mains to supply the test equipment).

Further it must be possible to deactivate protection devices or charge control processes, which lead to an opening of the output switches during the tests.

Advantage: This test configuration allows the simulation of high DC power values up to 600 kW on-site with less weight of the test equipment compared to other solutions with adjustable real loads or regenerative electronic loads.

Calibration of AC and DC electricity meters in the laboratory

MTE has a broad experience in the field of testing different electricity meters and hundreds of customized high precision meter test systems to its credit.

Based on its comprehensive product range and the modular system components MTE may cover all kind of standard requirements from the metering industry as well as upcoming adaptations in the course of EVSE and its components or specific AC and DC electricity meters.

The modular approach provides flexibility and enables MTE to select the optimal customer orientated solution for each single- or three-phase meter test system the customer requires to meet the changing needs in the metering world. It's the customer who chooses the degree of automation, the integration of various test modules and steps or the number of measuring positions and throughput of meters.

All key components of a test system are coming from the same and MTE's own single source.



Test bench for calibration of 10 (5 DUT with 2 each) three-phase AC electricity meters AC reference standard and power source, three-phase:

- Voltage range: 30 V ... 300 V phase-neutral (optional: 480 V, 600 V)
- Current range: 1 mA ... 120 A (optional: 200 A)

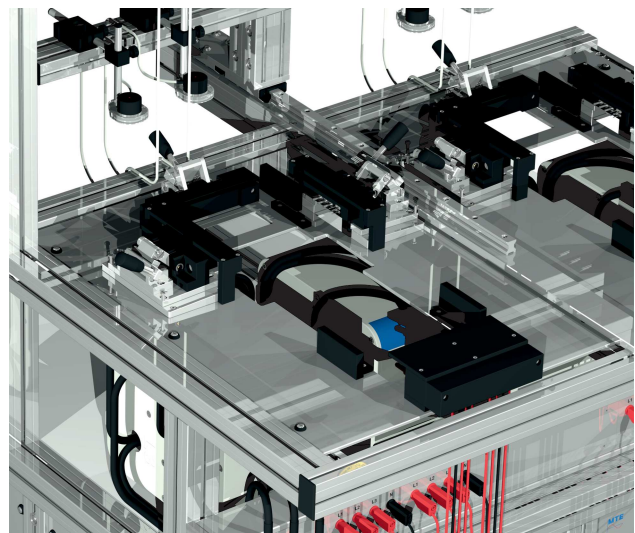
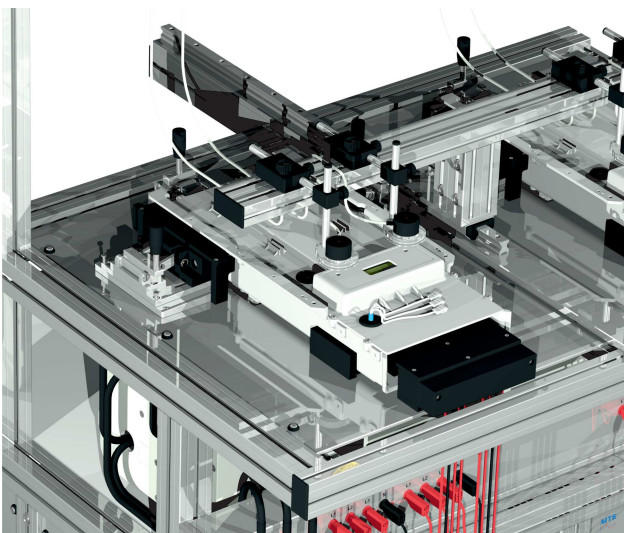

Calibration of DC electricity meters in the laboratory

1 to 6 Position Test System for DC Electricity Meters or DC Energy Measuring Units of EVSEs with U and I path connected

- Voltage range: 100 V ... 1000 V
- Current range: 5 A ... 600 A
- DC reference standard class 0.04 (6 channels)

If 2 or more DC electricity meters with closed link (voltage and current path connected) are tested and the test voltage is connected to the current at position 1, the following positions will see a lower test voltage, reduced by the voltage drop on the current path between the meters, which varies with the current amplitude.

To overcome this problem with variable test voltages influencing the accuracy of the calibration, a DC reference standard with 6 U channels is used to measure the exact test voltage at 1 up to 6 test positions individually. Together with the common current sensors these leads to 6 DC power reference channels with 6 pulse outputs $f_{ref\ 1} \dots f_{ref\ 6}$ connected to 1 up to 6 error evaluation modules SMM 400+. These are used for error measurements, if the DUTs are equipped with optical or electrical pulse outputs. Should no pulse outputs be available, register tests can be performed individual for each position.

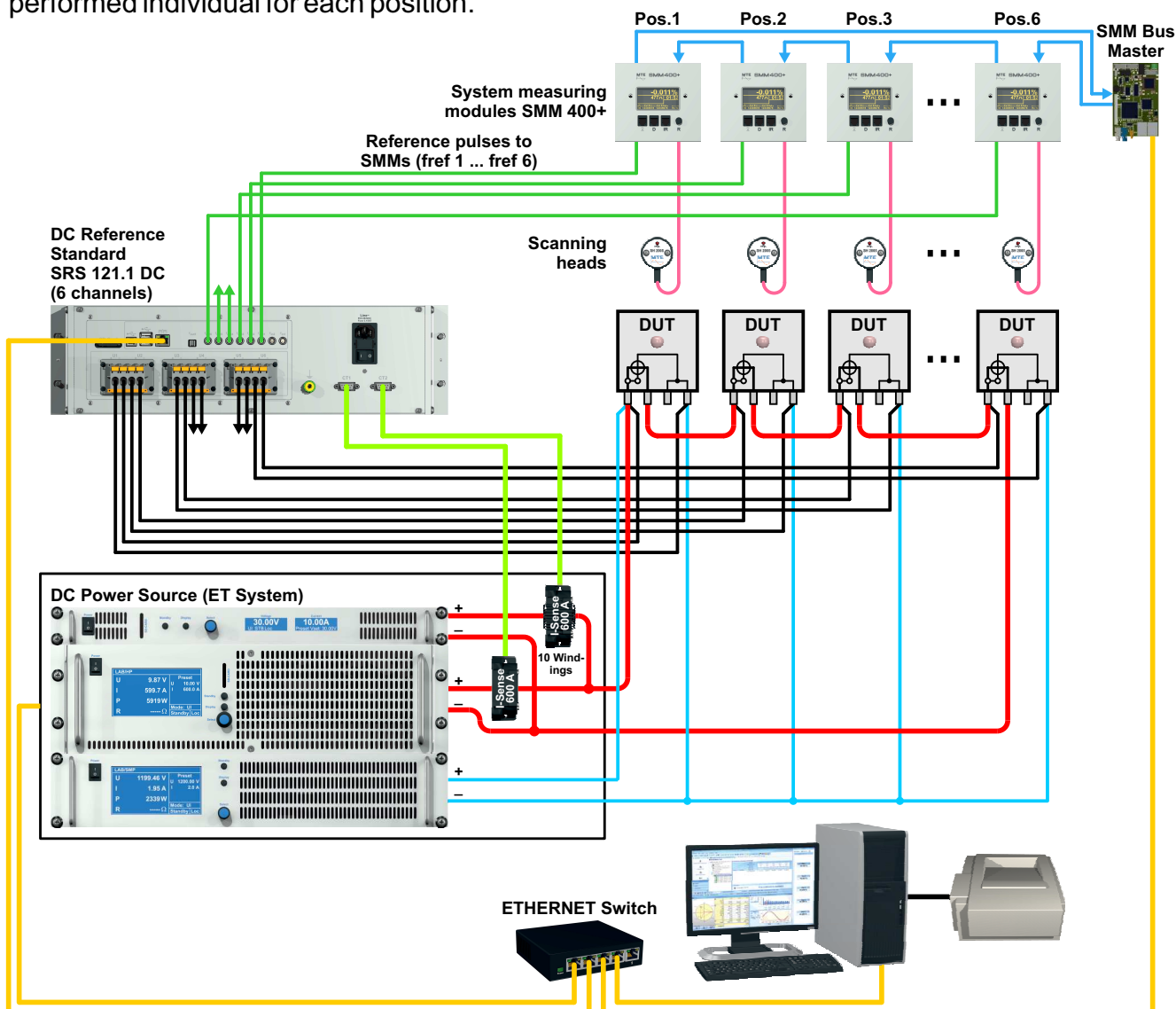

The DC Meter Calibration System is designed to test single-phase DC electricity meters with open and closed I-P links. It is fully electronic, using only solid state electronic components and is controlled by a PC via the integrated ethernet interfaces.

The system is equipped with following components:

- DC Power source with one DC voltage amplifier and two DC current amplifiers
- DC reference standard SRS 121.1 DC
- Control unit STE 10

DC Power Source

Fully static single-phase DC sources for the generation of voltage and current for the meters under test. The power sources works independently from the supply network.

DC Voltage amplifier

- Voltage range: 0 ... 1200 VDC | 2400 W
- Accuracy: $\leq \pm 0.2 \%$
- Stability: $\leq \pm 0.05 \%$

DC Current amplifiers

- Current range: 0 ... 80 ADC | 1200 W
0 ... 600 ADC | 10000 W
- Accuracy: $\leq \pm 0.2 \%$
- Stability: $\leq \pm 0.05 \%$

DC Reference Standard

The SRS 121.1 DC is a 6-channel single-phase reference standard for DC power / energy class 0.04 for verification of 1 up to 6 DC Meters or DC Energy Measuring Units of EVSEs (Electric Vehicle Supply Equipment) at the same time.

- Voltage range: 0.5 ... 1000 VDC
(1500 VDC on demand)
- Current range: 0.1 ... 600 ADC
- Accuracy: $\leq \pm 0.04 \%$



Project example

Test bench for calibration of 5 single-phase DC electricity meters DC reference standard and power source, single-phase:

- Voltage range: 100 V ... 1000 V
- Current range: 5 A ... 600 A

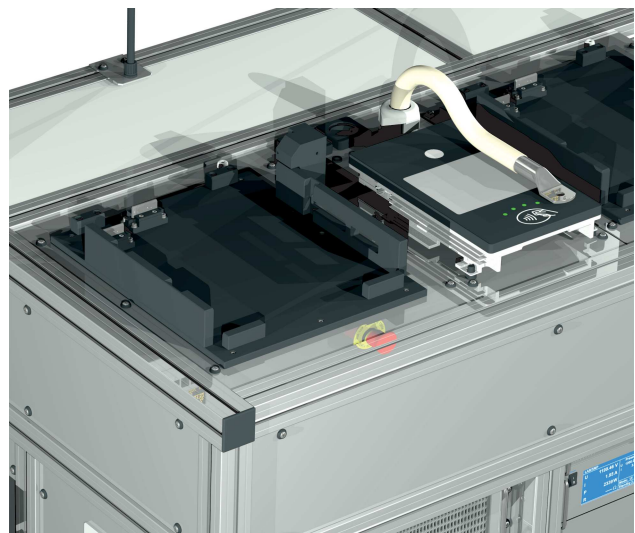
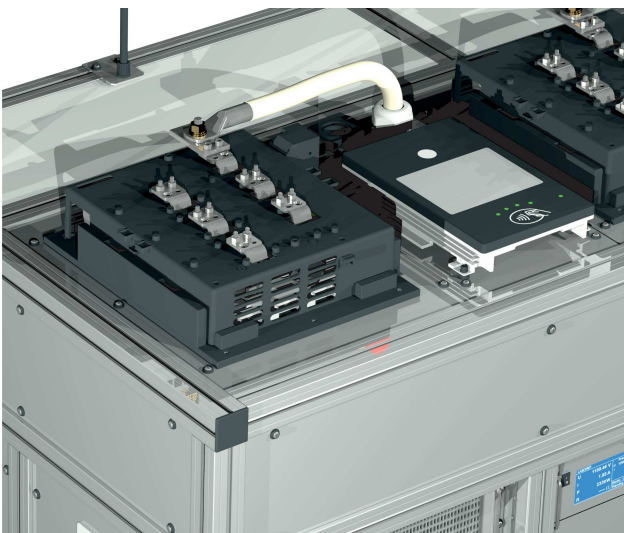

EMH Energie-Messtechnik GmbH receives DAkkS accreditation for DC Power / Energy measurements

The EMH DAkkS Calibration Laboratory got as one of the first among the calibration laboratories in Germany the DAkkS Accreditation for DC Power / Energy measurements up to 600 kW / 600 kWh.

Scope of Accreditation

- DC Voltage: 100 mV ... 1000 V
- DC Current: 10 mA ... 600 A
- DC Power: 1 mW ... 600 kW
- DC Energy: 1 mWh ... 600 kWh

Thus, EMH's accreditation to ISO/IEC 17025 guarantees the consistent and high quality of calibration services for MTE Meter Test Equipment and its customers in the field of portable and stationary DC test systems.



EMH Energie-Messtechnik GmbH DAkkS ISO/IEC 17025 accreditation Calibration and Measurement Capabilities for DC Measurements [ppm]

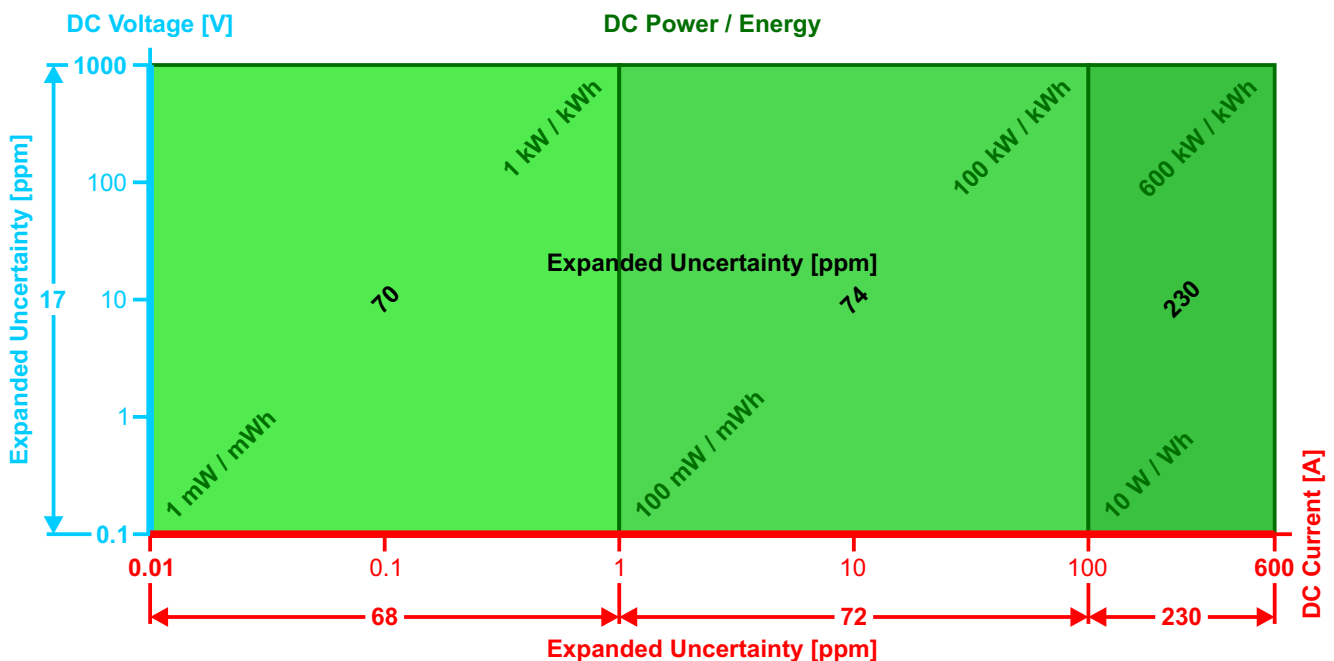

The following MTE leaflets are available:

Overviews:	Company Portrait / Portable Test Equipment / Stationary Meter Test Systems Automatic Test Systems / Transformer Monitoring / E-Mobility Testing
Comparator:	K2008
Portable Reference Standards:	PRS 600.3 / CALPORT 300
Portable Working Standards:	PWS 3.3 <i>genX</i> / PWS 2.3 <i>genX</i>
Portable Standards:	CheckMeter 2.3 <i>genX</i>
Portable Test Systems:	PTS 400.3 PLUS / PTS 3.3 <i>genX</i> / PTS 2.3 <i>genX</i> CheckSystem 2.3 / CheckSystem 2.1 / CheckSystem 2.1 S
Portable Power Sources:	PPS 400.3 / PPS 3.3 <i>genX</i> / CheckSource 2.3
Software:	CALegration®

MTE Meter Test Equipment

MTE Meter Test Equipment AG

Landis + Gyr-Strasse 1
P.O. Box 7550
CH-6302 Zug, Switzerland
Phone: +41-41 508 39 39
Internet: www.mte.ch
e-mail: info@mte.ch

EMH Energie-Messtechnik GmbH

Vor dem Hassel 2
D-21438 Brackel, Germany
Phone: +49-4185 58 57 0
Fax: +49-4185 58 57 68
Internet: www.emh.eu
e-mail: info@emh.de

MTE India Private Ltd.

Commercial Unit - 118 & 119, First Floor
Plot No. 10, Aggarwal City Square, District Centre,
Mangalam Place, Rohini Sector-3, Delhi 110085, India
Phone: +91-11 40218105
E-Mail: info@mteindia.in

EMH Energie-Messtechnik (Beijing) Co. Ltd.

Section 305, Building 2, Ke-Ji-Yuan
Nr.1 Shangdi-Si-Jie, Shangdi-Information-Industry-Base
Haidian District
Beijing 100 085, P.R. China
Phone: +86-10 629 81 227
Mobile: +86-139 0 103 6875
Fax: +86-10 629 88 689
e-mail: guo@emh.com.cn

MTE Meter Test Equipment (UK) Ltd

4 Oval View
Woodley Stockport
Cheshire SK6 1JW, United Kingdom
Phone: +44-161 406 9604
Fax: +44-161 406 9605
e-mail: info@mte.uk.net



MTE Meter Test Equipment AG

 Landis + Gyr-Strasse 1 • P.O. Box 7550 • 6302 Zug • Switzerland
Phone +41-41 508 39 39 • Internet www.mte.ch

12.2022_R06
Subject to alterations